SK700-II ADBLUE®

AdBlue dispensers adapted to fit your needs

- > Standalone, Combi or Integrated
- > Ensures maximum uptime and damage free filling
- > A reliable solution to meet any customer needs
- > Also available in ATEX version



Why SK700-II AdBlue®?

Tighter European emission limits for vehicles have strongly increased the demand for AdBlue® filling stations. However, AdBlue® can literally destroy filling equipment, as it is highly corrosive, temperature sensitive and crystallises in contact with air. Minor impurities can easily damage the expensive truck catalytic system.

The modular SK700-II AdBlue® range, now available in ATEX, is uniquely designed and field proven to meet the rigorous demands of AdBlue® filling. It will fit seamlessly with the rest of the solutions and systems on your forecourt.



Advanced Design

The SK700-II AdBlue® range incorporates the Coriolis meter, the industry's most advanced and corrosion proof measurement system.

The field proven SK700-II ensures maximum uptime and the Coriolis meter, without any moving parts, has no drift reducing the total cost of ownership.

Flexible Solution for different conditions

Gilbarco Veeder-Root has developed a heated hose system that prevents AdBlue from freezing and makes nozzle and hose handling very easy.

In addition, the new ATEX version allows you to combine AdBlue with Petrol and Diesel grades in the same unit allowing greater flexibility.

Technical Specifications

Technical Specifications & Standard Features

Hydraulics	Stainless steel coriolis meter AdBlue Stainless steel internal piping and connections Non return valve and filter AdBlue delivery – Pressure Flow rate for truck Adblue 4-40 l/min, flow rate for car Adblue 2,5-10 l/min. Power supply: 230V (+10% -15%), 50Hz ± 2Hz	
Electronics	Calculator Gilbarco Sandpiper-II LCD display (backlit) Interface: 2-wire, IFSF-LON, ATCL, PUMA LAN, ER3	
Mechanical	Electronics – Stainless steel valves Housing – Powder coated steel Hose management – Internal hose without retraction as standard Nozzles – ZVA, AdBlue hose reach 3,10m (without retraction) 3,50m (with retraction = option)	
Options	Elaflex swivel Break-away couplings Electromechanical totalisers Nozzle adaptor AdBlue preset Stainless steel hose column Stainless steel installation kit Stainless steel cladding Enhanced corrosion protection SK700-II standard options	
Versions	Base	Fully Heated
Hydraulic cabinet heater	not included	Included
Hose column heater	not included	Hose with trace heater
Power consumption heating	-	700 watts
Min. operating temperature	down to -10°C	down to -25°C (optional down to -40°C)
AdBlue breakaway	Optional	Available up to -25°C
Nozzle cover	Optional	Optional
Certifications	MID & Atex (Optional)	MID & Atex (Optional)

Isolation needed for temperature < -25°C for all models. ATEX available up to -40°C

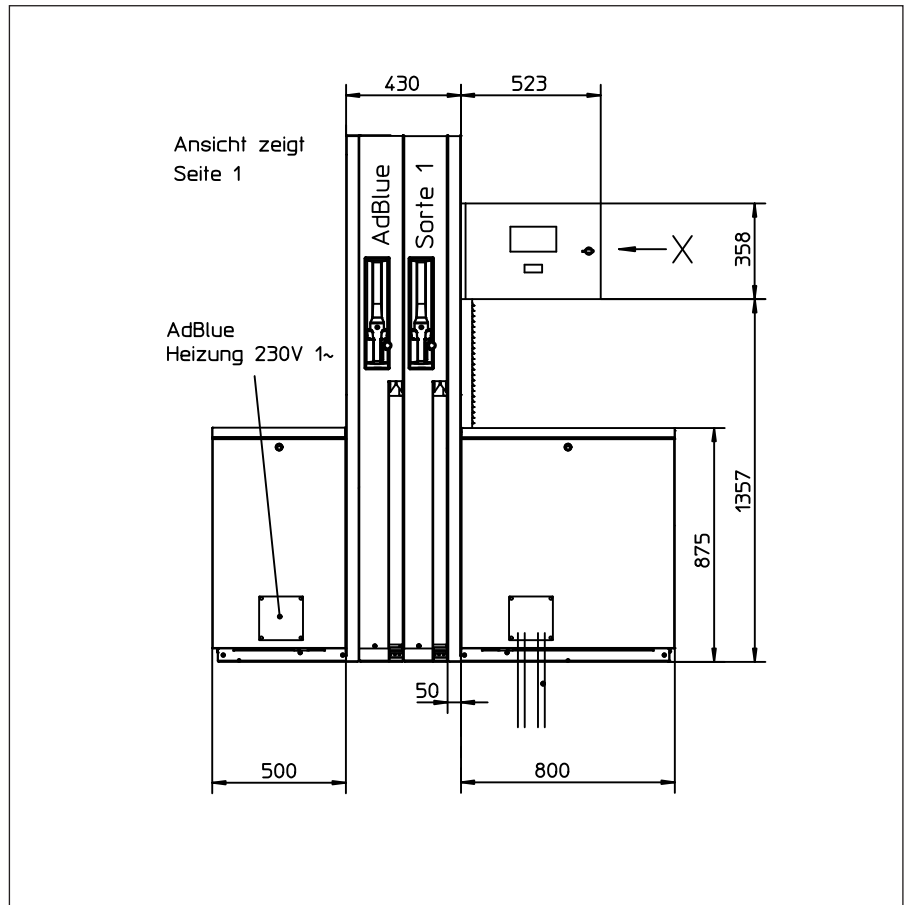
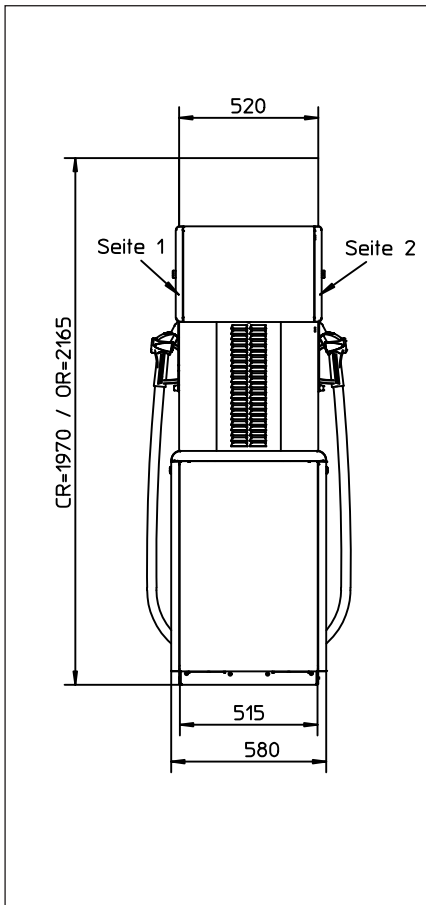

AdBlue® Dispensing Solutions

Frontier AdBlue® Dispensers for Cars and Trucks, with Atex and MID approvals. An addition to our flagship SK700-II platforms

Frontier AdBlue® Dispensers for Cars and Trucks, with Atex and MID approvals. An addition to our flagship SK700-II platforms

- > Available for either cars or trucks, or both
- > Can be Standalone AdBlue Dispenser or Combi dispenser with Diesel or Integrated with above ground tank: 1,100, 4,000, 5,000, 7,500 or 10,000 litre
- > Models from 1-hose/1-grade to 4-hose/2-grade with up to 4 displays
- > Available with ATEX and MID approvals
- > Corrosion-proof Stainless Steel with no moving parts, and no drifts



Our Comprehensive Range of AdBlue® Dispensers for Cars and Trucks demonstrate Gilbarco Veeder-Root's commitment to introducing environmentally friendly fuels at the forecourt.



SK700-II AdBlue®
Standalone for cars and trucks
Compact and robust



SK700-II AdBlue®
for cars and trucks
For expanding forecourt needs
Flexible and Modular
Multi-grade dispensing solution



SK700-II AdBlue®
Integrated
Plug and play

Why Gilbarco Veeder-Root?

Thanks to Gilbarco Veeder-Root's SK700-II range for Alternative Fuels LPG, AdBlue[®], CNG, Biodiesel and E85 are now easy to integrate into your forecourt.

With these configurations it is now possible to deliver Alternative Fuels alongside other fuel grades from the same dispenser. The SK700-II range for Alternative Fuels allows you to maintain a uniform image across your alternative and conventional fuel dispensers. The safety, efficiency and reliability offered by Gilbarco Veeder-Root's robust, low maintenance solutions will continue to keep your site up and running.

The Fail Safe AdBlue[®] Filling Solution

Fail Safe

The pressure delivery system avoids crystallisation and dispenser hydraulics are corrosion proof, while automatic heating prevents AdBlue from freezing.

Versatile

Choose from Standalone, Combi and Integrated configurations to build the right solution for your forecourt.

Design Matters

The SK700-II AdBlue incorporates the most advanced metering system in the industry – a stainless steel Corolis meter. It has no moving parts to ensure it will not block and maximises uptime.

Proven

AdBlue[®] freezes at -11°C. SK700-II AdBlue[®] installations have continuously performed in countries like Finland at temperatures down to -40°C.

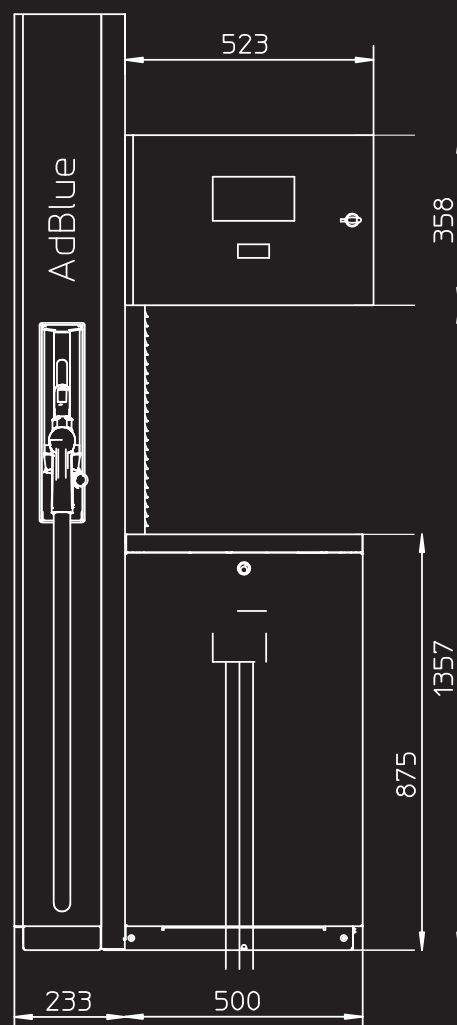

Gilbarco Veeder-Root Solutions

With a universal range, global reach, deep-rooted expertise and superior customer service, Gilbarco Veeder-Root is committed to building better business for its customers.

Pumps & Dispensers

Robust, reliable, accurate and secure technology

Our Pumps and Dispensers feature flexible, innovative and upgradable technology. They not only grow with your business, but also improve the forecourt experience for your end-users.

By focusing on the unique requirements of our customers, we deliver high quality and reliable solutions that are designed to support better business now and in the future.

Our range includes:

- > Multi-Product Dispensers
- > Single and Dual Dispensers
- > Alternative Fuels
- > Applause Europe (multimedia)
- > Submersible Turbine Pumps
- > Commercial Dispensers



Business Support

Protect assets and drive operational efficiency

Our Business Support solutions minimise downtime and disruption by providing the tools, services and technology necessary for our customers to get more from their businesses.

With an extensive reach throughout Europe, you can be assured that no matter where your business takes you, our comprehensive range of services will always be available.

Wetstock Management

Improve performance, uptime and security

Our comprehensive range of compliant and reliable Wetstock Management solutions offer you advanced engineering and a responsive service. Scalable and customisable, our tools provide control, security and data across networks of all sizes anywhere in the world.

Ultimately, our solutions enable you to stay compliant and in control.

Retail Solutions

Maximise profitability and minimise overheads

Our leading Point of Sale, Head and Back Office Systems and forecourt controllers create new business at the pump and enable deeper insights into stock, logistics and security.

Working alongside our wide range of products and services, our Retail Solutions are designed to work for you.

AdBlue® is a registered trademark of Verband Der Automobilindustrie (VDA).

Building Better Business

Tel: +44 (0) 1268 533090
E-mail: eumarketing@gilbarco.com
Visit us: www.gilbarco.com/eu

Follow us on:
LinkedIn: [gilbarco-veeder-root-europe](https://www.linkedin.com/company/gilbarco-veeder-root-europe)
Twitter: [gvr_europe](https://twitter.com/gvr_europe)

